

For personal use only



**4X4 ACCESSORIES**

**MACQUARIE CONFERENCE  
8 MAY 2024**

**Lachlan McCann**  
Chief Executive Officer



For personal use only



For personal use only

# ARB WE'VE COME A LONG WAY

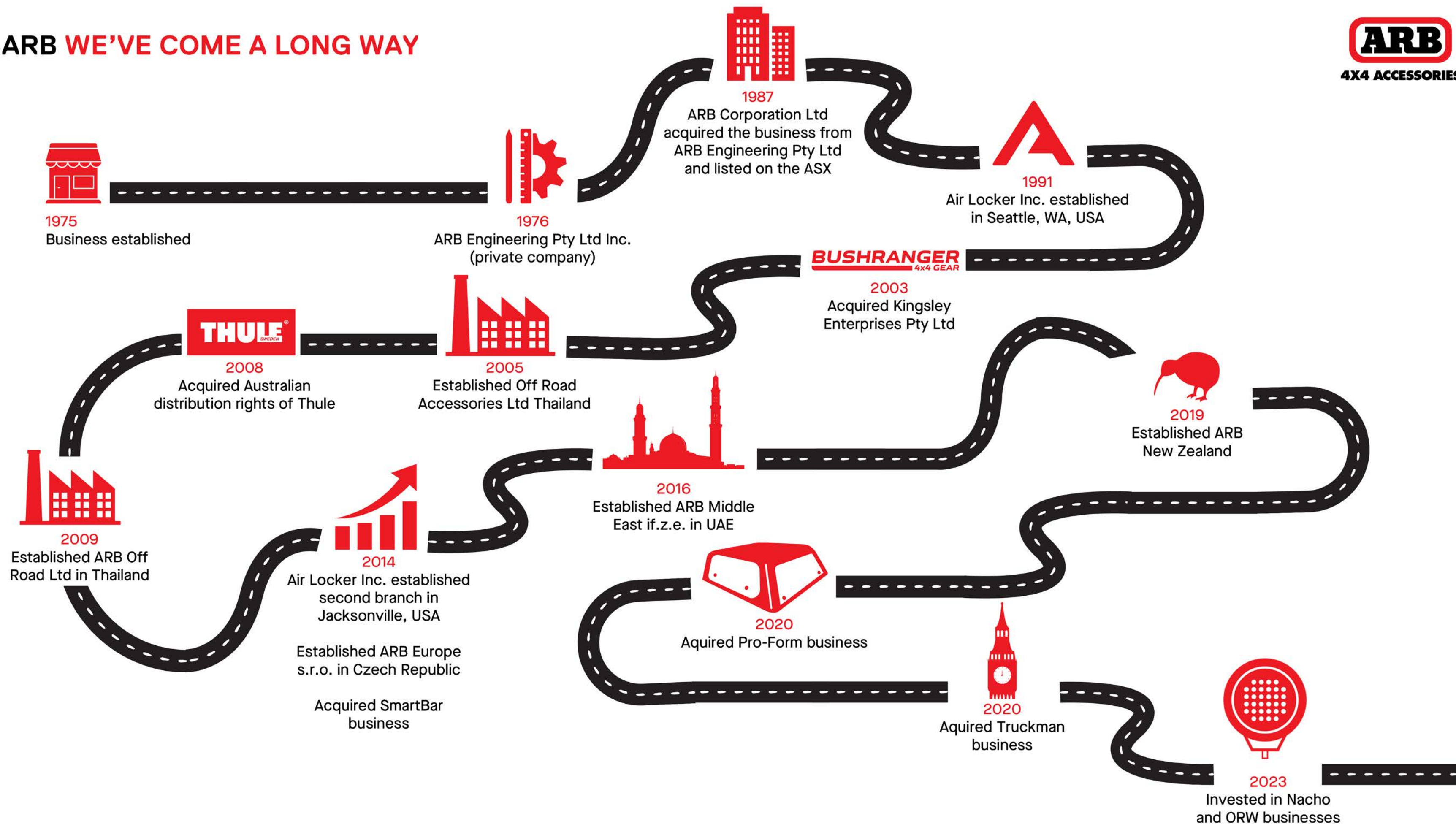

For personal use only

# ARB COMPANY SNAPSHOT



**49** YEARS

Industry Experience  
- EST 1975 -

**\$3.1B**

Market Capitalisation  
ASX S&P200

**2,120**

Employees Worldwide  
8 International Offices

**100+**

Exporting to 100+  
Countries



# ARB PERFORMANCE LAST 10 YEARS



## SALES REVENUE 10 YEAR CAGR OF 8.7% TO FY2023

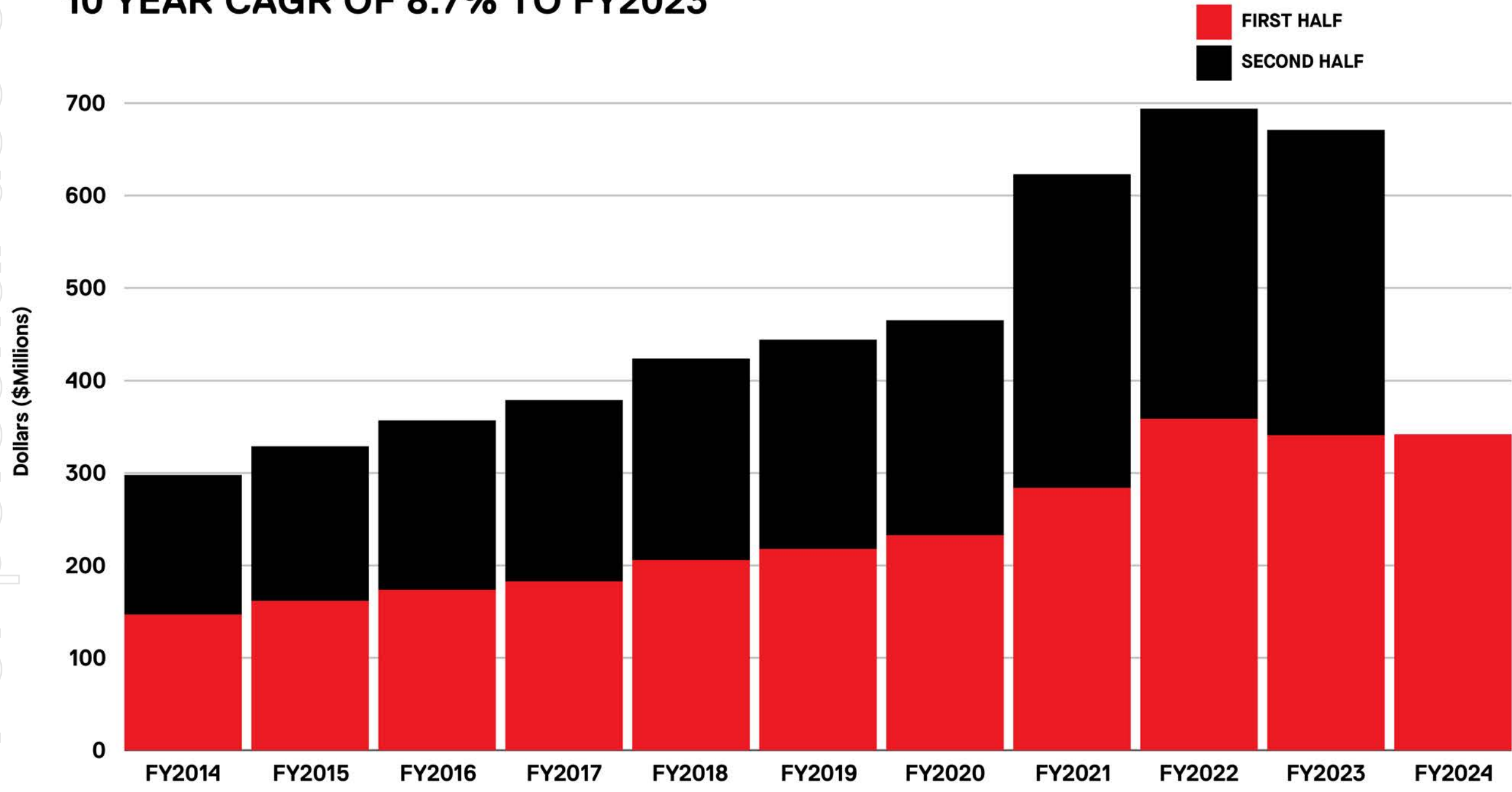

- 10 year Compound Average Growth of 8.7% p.a.
- Sales revenue growing in FY2024 following significant sales growth achieved in FY2021 and FY2022

For personal use only

For personal use only

# ARB PERFORMANCE LAST 10 YEARS



## NET PROFIT AFTER TAX 10 YEAR CAGR OF 7.6% TO FY2023

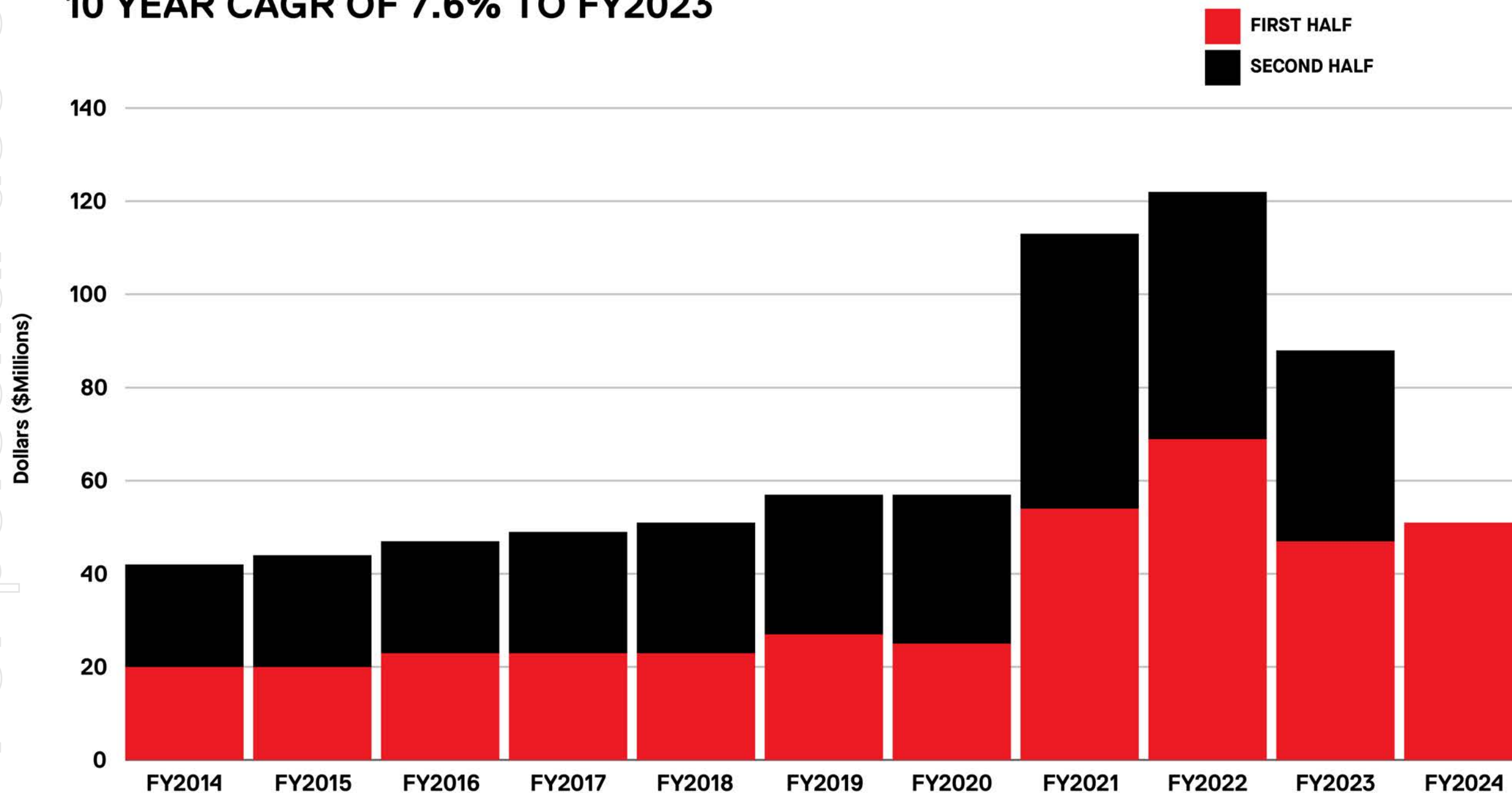

- 10 year Compound Average Growth of 7.6% p.a.
- Step change achieved in Net Profit after Tax following sales revenue growth from FY2021

# ARB PERFORMANCE LAST 10 YEARS



## DIVIDENDS PER SHARE ALL DIVIDENDS FULLY FRANKED

■ INTERIM DIVIDEND  
■ FINAL DIVIDEND

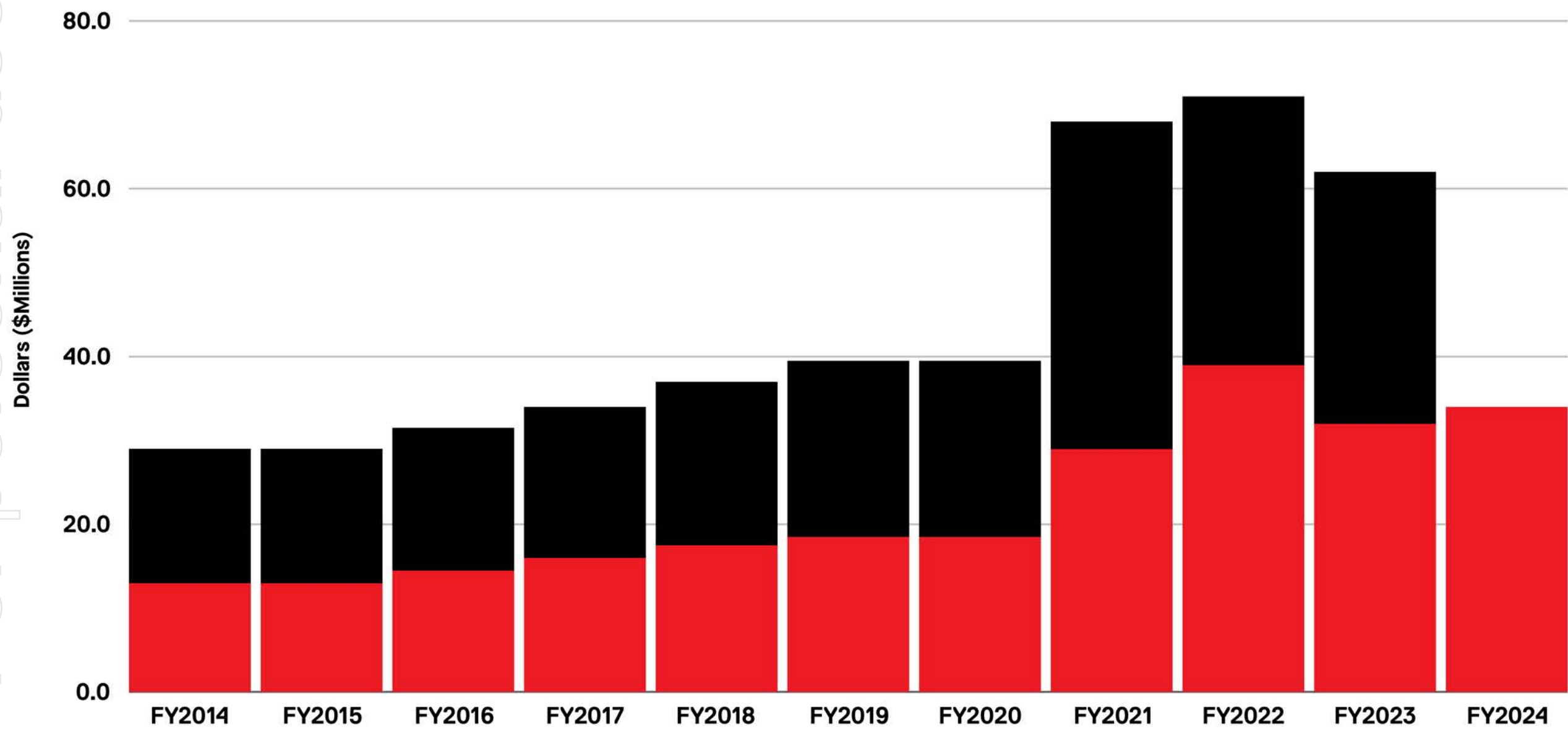

\*Excludes special dividend of 100 cents in FY2015

- Fully franked dividends paid consistently over the last 10 years in line with profits earned
- Dividends fully funded out of available cash and a DRP/BSP for the past few years, i.e., no company debt since FY2018 and no net debt since FY2008

For personal use only

# ARB SALES REVENUE SUMMARY 9 MONTHS TO MARCH



## SALES GROWTH CONTINUING

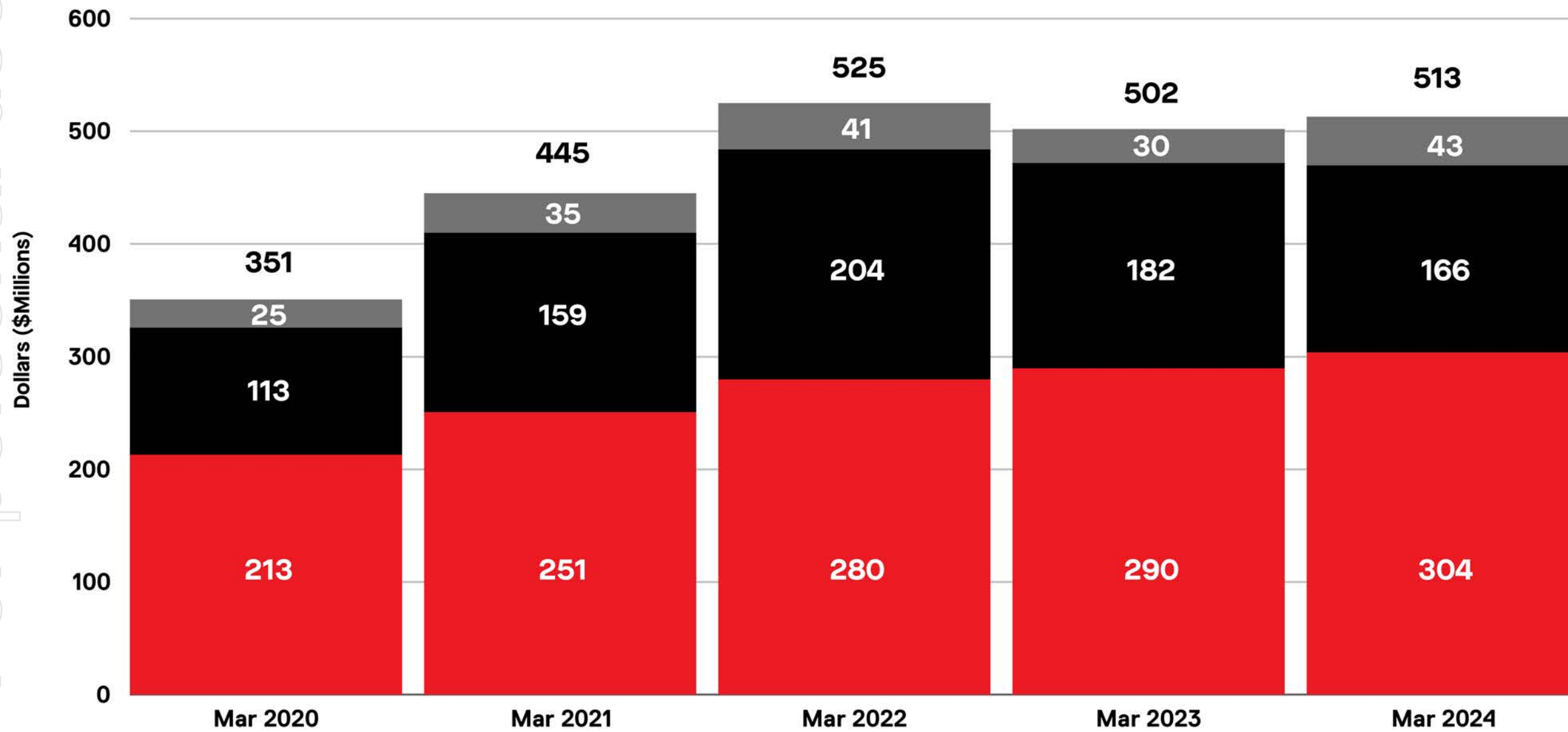

**Q3 FY2024**

**UP 6.4%**

**9 MONTHS TO MARCH**

**OEM  
UP 42.2%**

**EXPORTS  
DOWN -8.8%**

**AUSTRALIAN  
AFTERMARKET  
UP 4.6%**

**TOTAL SALES  
UP 2.1%**

For personal use only



# ARB CAPITAL EXPENDITURE 10 YEARS



## CAPITAL EXPENDITURE (\$MILLIONS)

|                 | Land & Buildings | Plant & Equipment | Total        | Major Capital Expenditure in recent years includes:                              |
|-----------------|------------------|-------------------|--------------|--|
| FY2014          | 10.3             | 6.0               | 16.3         |  |
| FY2015          | 32.8             | 13.7              | 46.5         | Melbourne, AU Head Office (FY2015)   |
| FY2016          | 3.2              | 12.7              | 15.9         |  |
| FY2017          | 10.6             | 9.7               | 20.3         | Thai Global Distribution Centre (FY2017-FY2019)                                  |
| FY2018          | 28.0             | 12.1              | 40.1         | Melbourne, AU National Distribution centre (FY2018)                              |
| FY2019          | 12.7             | 10.9              | 23.6         | Retail store upgrades (ongoing)  |
| FY2020          | 7.6              | 10.1              | 17.7         | Manufacturing equipment (ongoing)  |
| FY2021          | 20.1             | 13.0              | 33.1         | Thai factories (FY2021-FY2022)   |
| FY2022          | 44.5             | 13.6              | 58.1         | NZ factory (FY2022-FY2024)   |
| FY2023          | 21.6             | 19.0              | 40.6         | Melbourne, Australia, National Warehouse (FY2023)                                |
| FY2024 FORECAST | 31.1             | 14.9              | 46.0         | Melbourne, Australia, Head Office Redevelopment (FY2022-ongoing) & SmartBar site |
| <b>TOTAL</b>    | <b>222.5</b>     | <b>135.7</b>      | <b>358.2</b> |  |

- ARB has consistently invested in capital expenditure to facilitate growth
- Significant investment in land & buildings over the past four financial years
- Capital expenditure predominantly funded out of operating cash flows with no net debt since FY2008

For personal use only

For personal use only

# AUSTRALIAN AFTERMARKET



For personal use only

# ARB DISTRIBUTION TO MARKET AUSTRALIAN AFTERMARKET



**74** ARB STORES IN TOTAL NATIONWIDE

**30** ARB COMPANY OWNED STORES

**44** ARB BRANDED STORES

**150+** STOCKISTS AND INDEPENDENT RESELLERS

**5** STATE DISTRIBUTION CENTRES

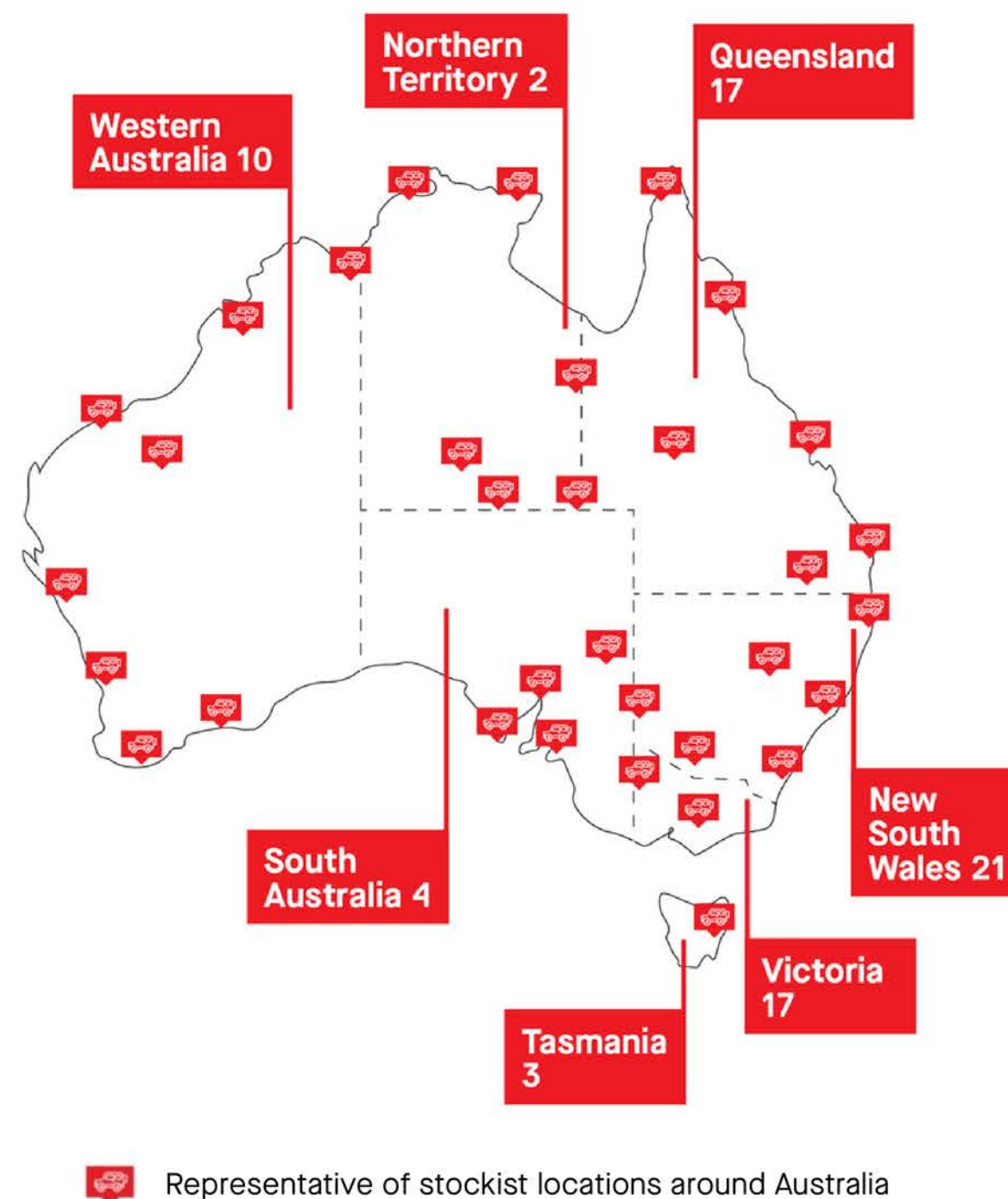

The Company's flagship store roadmap is well developed to accelerate new stores.

ARB store upgrades to the flagship model include Osborne Park WA and Canberra ACT, with Albury NSW nearing completion. Mornington Vic and Bundaberg Qld are in the early stages of construction. Jayco Adelaide SA opened in March 2024.

ARB continues to work with independent store owners as they develop plans for additional stores within their territories.

Ford Licensed Accessory program continues to grow. New products from ARB are routinely added to the program as well as development of new strategic initiatives between Ford and ARB.

**Australian Aftermarket remains strong.**

# ARB NATIONAL SALES **NEW STORE UPDATES**

## **ALBURY**

- Fantastic looking building in a very prominent location.
- Property now handed over and received from the builders.
- Internal fitout now commenced.
- Expected to be trading from the new location at the end of May 2024.

Finishing touches are underway



## **BUNDABERG**

- Build well underway and has been progressing to schedule.
- Team prepping current site for an efficient changeover.
- Expected to be open and trading mid July 2024.



## **MORNINGTON**

- Progress of build going to schedule with expected handover at the start of June 2024.
- Internal fitout to commence thereafter with an expected open date of end July 2024.



## **TOOWOOMBA**

- Heads of agreement has been signed for ARB to take ownership of ARB Toowoomba Qld, a privately held store. Business owner is retiring.
- Significant market with a broad geographic footprint.
- Management plans currently underway in preparation of ownership.
- Planned takeover date 1 July 2024.

For personal use only

# ARB TARGET NEW VEHICLE SALES AUSTRALIA Q3 FY2024 YTD



Number of Vehicles sold; Percentage change FY24 v FY23

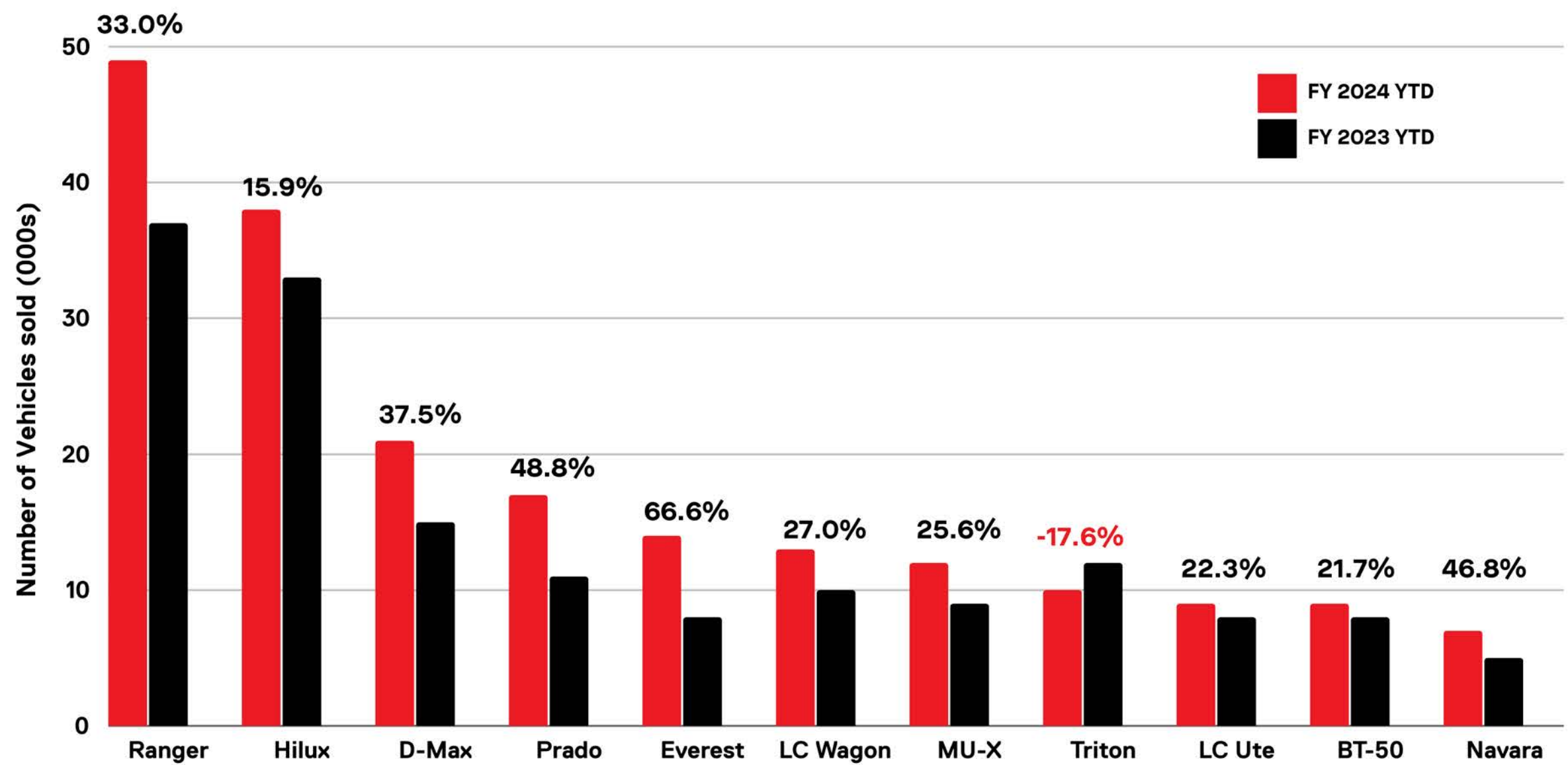

- Improved new vehicle supply for the first three quarters of FY2024 compared with the prior financial year
- Strong growth in key vehicles including the Ford Ranger and Toyota Hilux pick-ups, the Ford Everest and Toyota Prado SUVs and the Toyota Landcruiser

## ARB NATIONAL FITTING PERFORMANCE

Fitting capacity continues to be a key opportunity for ARB. Gradual improvements to employee retention, skill development and total fitters are contributing to improved fitter productivity in recent months.



### ENGAGEMENT

- Fitter turnover continues to trend positively. In a rolling 12-month period, staff retention has improved 30%.
- Over the same rolling 12 months, fitter staff numbers have improved 9%.
- Fitter pathway and fast-track induction programs are progressing well.
- Currently, experienced workshop fitters with 3+ years of continual service are at the highest level since April 2022.



### PERFORMANCE

- Increased retention and employee tenure has gradually improved workshop productivity.
- Overtime as a percentage of total fitting continues to increase.
- 10 additional international fitting employees have been contracted and will commence in H1 FY2025.



For personal use only

# INTERNATIONAL



# ARB NEW STORE HAMILTON GRAND OPENING



**FIRST FLAGSHIP ARB SHOWROOM OUTSIDE AUSTRALIA.  
PRIME RETAIL LOCATION ON WAIKATO EXPRESSWAY.  
LARGE FORMAT 450SQM SHOWROOM. PROVISION 12 HOISTS.  
NZ \$10M UPGRADE RETAIL, WAREHOUSING & MANUFACTURING.**

- Investment reaffirms ARB's commitment to New Zealand market, both as a manufacturer and retailer.
- VIP event was held on 11 April 2024 for wholesale customers, dealership groups and suppliers.
- Grand opening held on 13 April 2024 was a great success. 500+ customers in attendance on the opening day.
- Celebration with employees for official opening of NZ head office upgrades.





## SALES



- USA sales have returned to YOY growth in Q3 FY2024 despite challenging market conditions.
- Improved inventory, enhanced distribution through Dallas DC and addition of eCommerce have supported the growth.
- Various initiatives in place through aftermarket business to optimise Toyota USA brand association.
- US automotive aftermarket remains flat.

## SEATTLE RETAIL



- Seattle retail site remains on schedule for opening in Q2 FY2025.
- Civil and building permits have been submitted to council.
- Construction is due to commence in Q1 FY2025.

## WWW.ARBUSA.COM

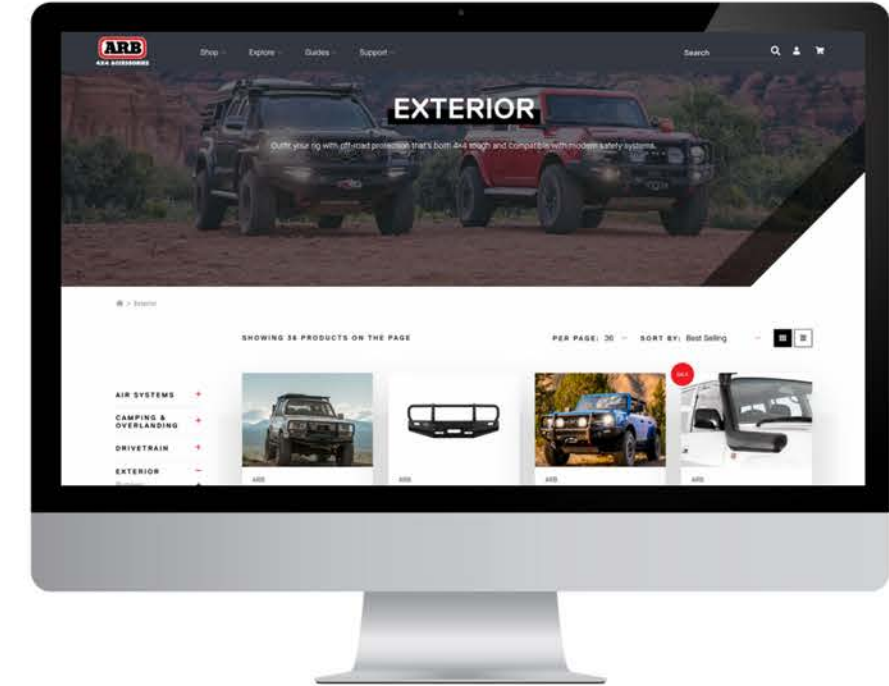

- USA eCommerce business continues to trend positively.
- Volume and value of orders received and shipped continue to increase.
- Consumer insights and related website optimisation continue to improve.
- Product mix of non-fitted consumer accessories and bulky vehicle specific product remains under review.

**USA sales outlook trending positively.**

## ARB USA OEM UPDATE



## TACOMA TRAILHUNTER

- Brand partner for Tacoma Trailhunter model: Rear Bumper, Recovery Points, BedRack, Old Man Emu Suspension.
- Supply of in-line production products and dealer installed products has commenced.
- Fantastic market feedback from wholesale and retail customers.

**TRAILHUNTER**



## 4RUNNER TRAILHUNTER

- Brand partner for 4Runner Trailhunter model: Roof Rack and Old Man Emu suspension.
- Model launched on 10 April 2024.
- Launch content included ARB Earth Camper.
- Fantastic market feedback from wholesale and retail customers.
- Product supply to commence in Q2 FY2025.

For personal use only

# ARB USA OEM UPDATE



For personal use only

# ARB USA OEM UPDATE

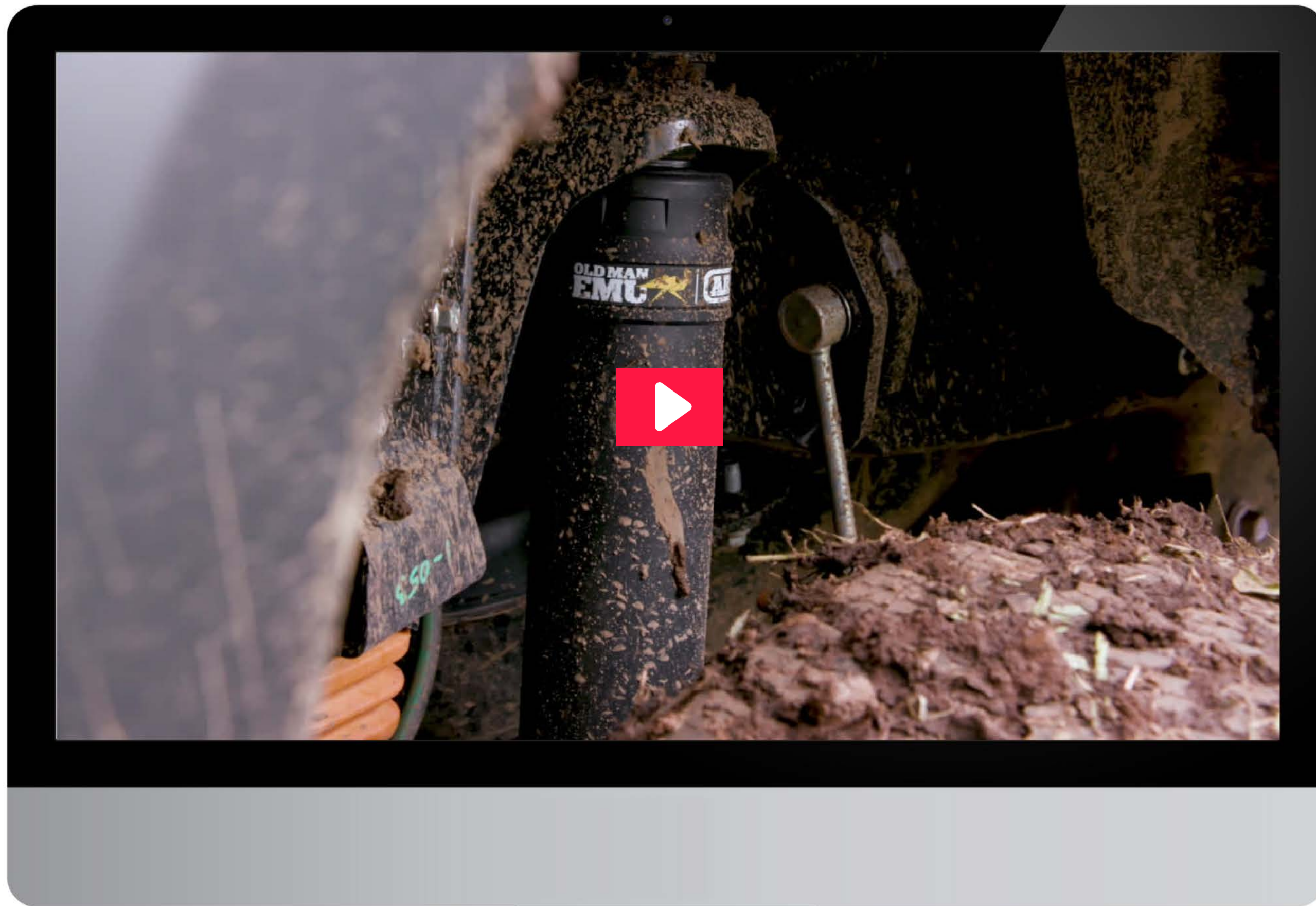

# ARB USA BUSINESS ASSOCIATES ORW UPDATE



30% Ownership Interest

Glendale  
Grand  
Opening



- Glendale AZ store open. Grand opening held Saturday 13 April 2024. Excellent open day which exceeded expectations. ARB well merchandised.
- Contract has been signed for store 11 in Denver, CO. Store expected to open in Q1 FY2025.
- Further stores locations currently under review.
- ARB has leased 1,000sqm warehouse in Corona, CA to support ARB / OME stock into ORW stores.



For personal use only

## ARB USA BUSINESS ASSOCIATES NACHO UPDATE

# NACHO

DRIVEN BY **ARB**

49% Ownership Interest

- NACHO order intake exceeding expectations albeit off a low base.
- NACHO Grande 8" light launched with pre-orders being taken. Excellent market feedback with strong demand received post-launch.
- NACHO awarded contract to supply 8 x Quatro lights on the Chevy Silverado FOX Factory Edition vehicle. First major contract for NACHO and great market recognition to partner with FOX.
- Product development pipeline continues to expand.
- NACHO lights due to go on sale in Australia in Q1 FY2025.



For personal use only



## ARB IP PROTECTION

**ARB's investment in design, innovation and brand development is supported by detailed intellectual property (IP) protection.**

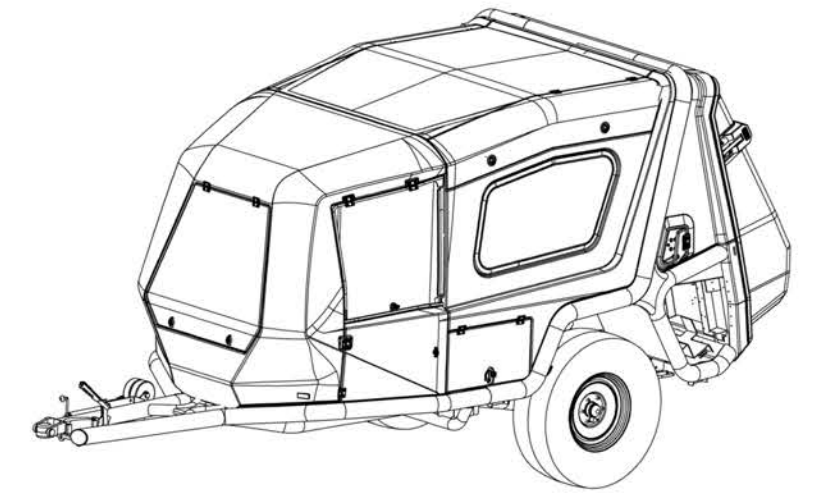
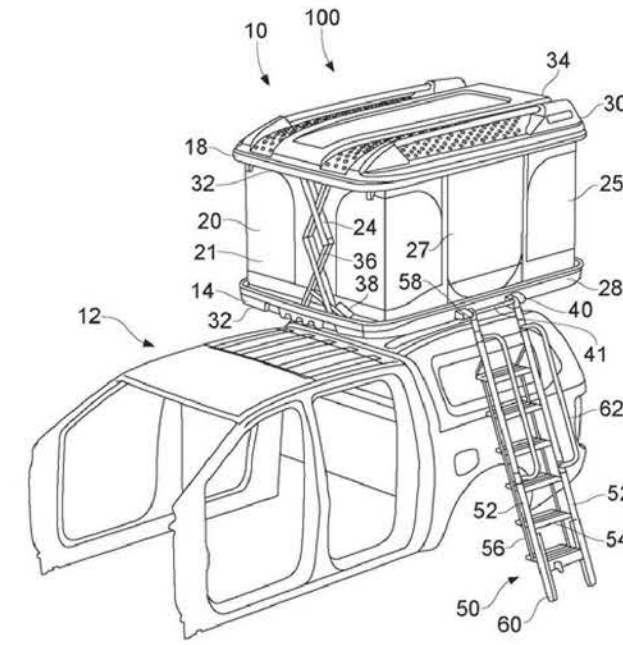
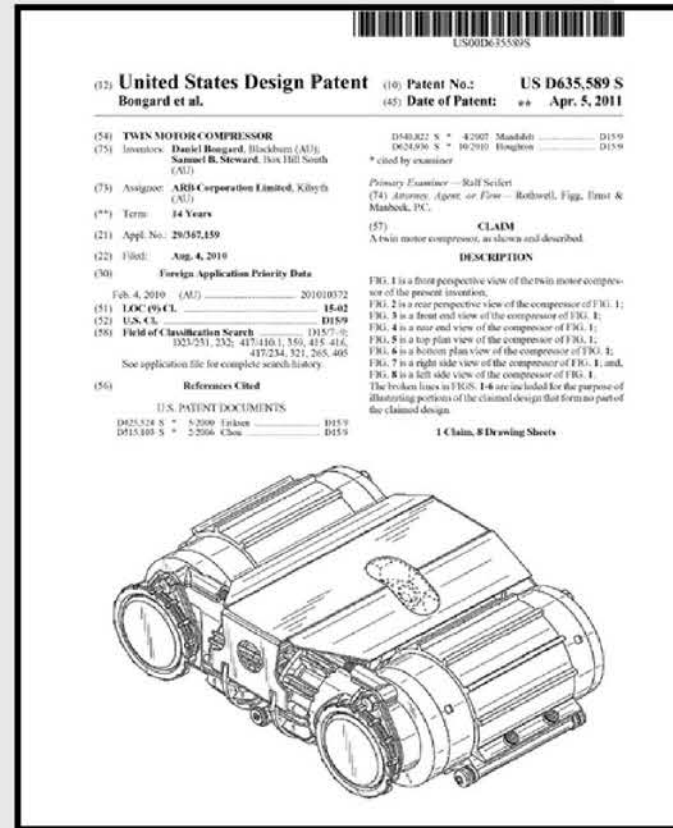

ARB's investment in design, innovation, and brand development is supported by securing robust registered intellectual property (IP) rights



ARB's IP portfolio includes 147 registered industrial designs, 20 enforceable patents, and 216 registered trade marks



ARB brands are covered by trade marks registered around the world.



ARB actively monitors competitor activity for infringement of its IP, and has recently successfully enforced its IP rights in Australia, China, and the USA







## AUSTRALIA MANUFACTURING

- Commitment to Australian manufacturing.
- 350 manufacturing employees in Australia across Melbourne, VIC head office factory and Adelaide, SA SmartBar factory.
- Competitive advantage in speed to market, engineering design for manufacture and product prototyping.
- Increasing investments in automation

## THAILAND MANUFACTURING

- ARB's manufacturing engine-room.
- Three factories and one distribution centre.
- 100,000 sqm under roof.
- 800 manufacturing employees.
- Toyota Manufacturing Quality systems for USA contracts in place.
- Flexible manufacturing for future programs.

A look behind the Thai manufacturing curtain...



For personal use only



For personal use only

# ARB PRODUCTS ALTITUDE ROOFTOP TENT LAUNCH

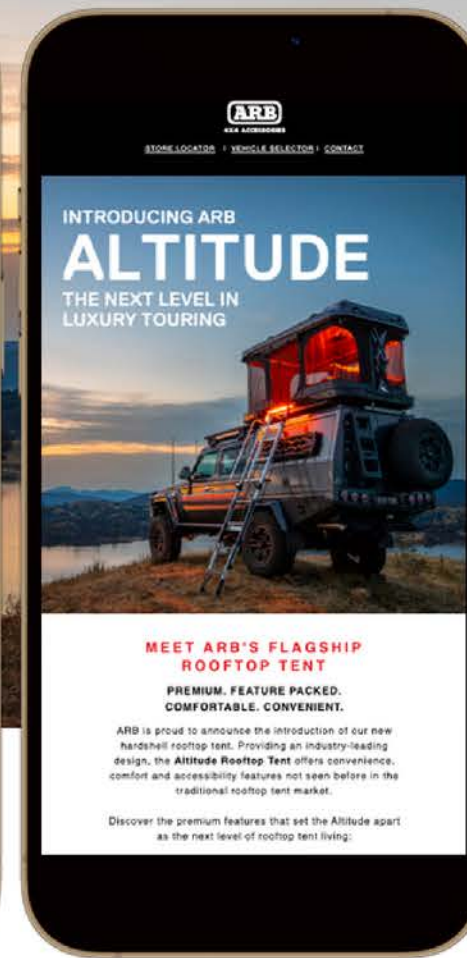
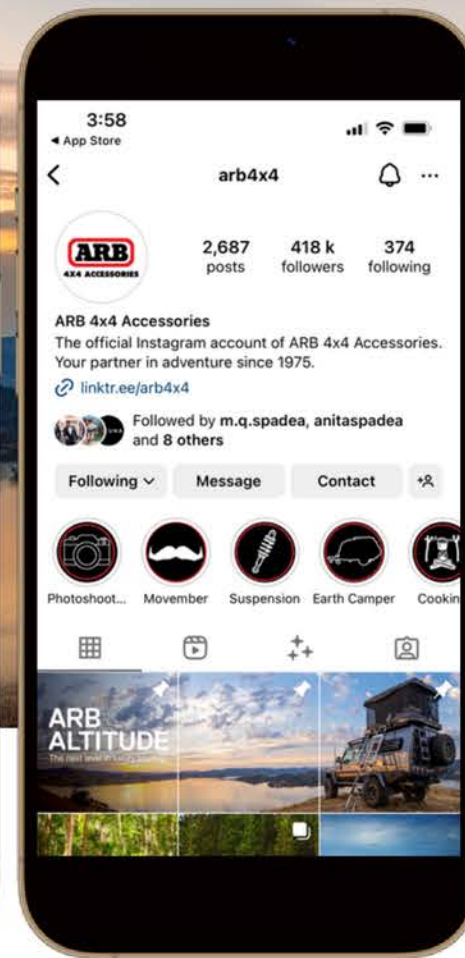
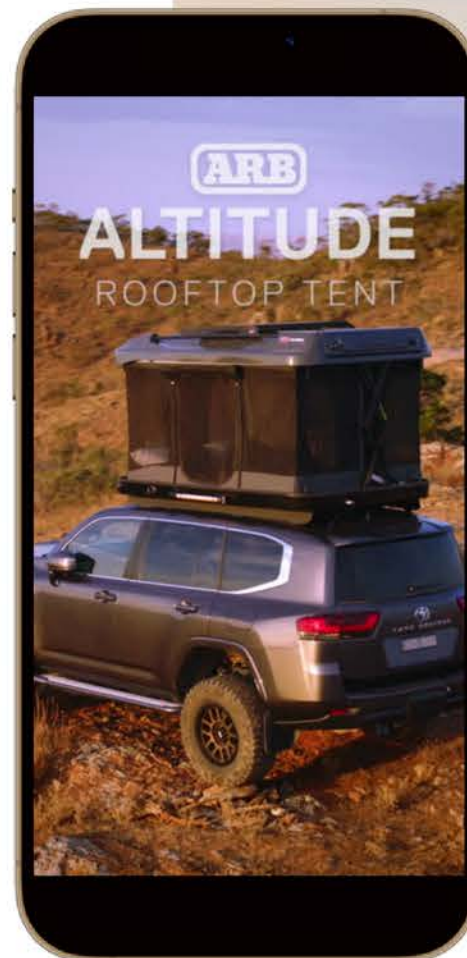
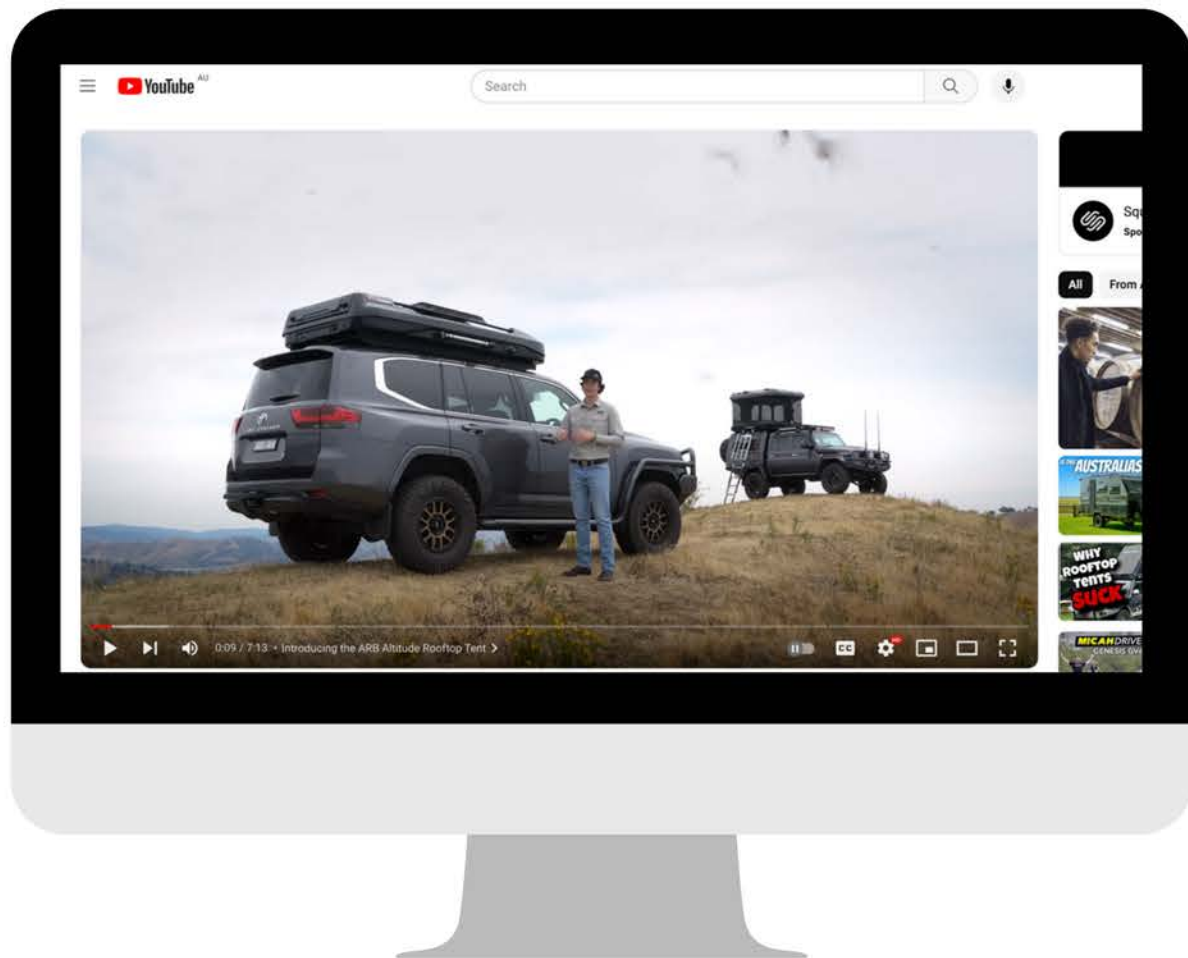

## MARKETING

Very high rates of engagement on-line both in Australia and international markets.

**370+** INTEREST REGISTRATIONS VIA OUR WEBSITE

**29k+** VIEWS ON OUR YOUTUBE WALK-AROUND VIDEO

**64k** E-MAIL OPENS AND 3.2% CLICK THROUGH RATE\*

**45k** PLAYS OF LAUNCH VIDEO IN AU FACEBOOK



## 4X4 SHOW

Response to launch of Altitude has been very positive. Excellent response from ARB staff, ARB store owners and the public at the unveiling at the Brisbane 4X4 show.

\*ARB average open is 1.9% via database

For personal use only



## EARTH CAMPER



- Interest in the Earth Camper remains positive.
- Supply to the market remains constrained. On-going enhancements to production process will be complete in Q1 FY2025 when existing backorders will be satisfied.
- Exposure through Toyota USA marketing is expected to support our USA launch.
- Compliance work for the USA and other International markets continues on track for completion within 2024.

## MT-64 SHOCK ABSORBER



- Product now in market globally.
- Initial demand has exceeded expectations despite launching with a limited range.
- Additional plant and equipment added to meet demand.
- 24 months of application engineering has been planned to expand the MT-64 range.
- Compliment of good-better-best range complete with the Old Man Emu suspension line-up.

## ELECTRIC VEHICLE - EV



RIVIAN

- ARB through OEM relationships and internal initiatives continues to explore the future of accessories on electric vehicles.
- ARB has imported to Australia and is currently working on our understanding of the Rivian pick-up.
- ARB is currently working on product development with various hybrid platforms.

## ARB OUTLOOK



- ARB's Aftermarket order book remains strong. The Company has recently strengthened its fitter capacity and is accelerating its store development programme.
- ARB's Export order book is trending positively with sales growth of 2.1% achieved in Q3 FY2024.
- ARB continues to strengthen key initiatives in the US market including:
  1. Toyota USA Trailhunter program and associated brand development.
  2. New e-comm platform providing a direct channel to grow retail sales of ARB branded products in the USA.
  3. Establishment of a new ARB branded retail store in Seattle, WA, scheduled to complete Q2 FY2025.
  4. Recent ORW investment (US retail stores).
- Sales to OEMs should continue to grow in FY2024 and into FY2025 based on contracts already in place.
- New vehicle supply and lead times have improved globally.
- Sales growth was achieved in each of the Australian Aftermarket, Export and OEM sales channels in Q3 FY2024.
- The outlook is trending positively with favourable trading conditions expected to continue into H1 FY2025.

### **The Board believes that the Company is well-positioned to achieve long-term success through:**

**Expansion of the Australian and NZ Aftermarket with new and upgraded retail stores and stockists.**

**Strategic partnerships with key OE customers in Australia and the USA.**

**Increased distribution and manufacturing capacity to accommodate future growth.**

**A strong balance sheet with no debt.**

**A pipeline of new product developments and releases.**

**A well balanced management team with a blend of long-term ARB and experienced external executives.**



For personal use only



4X4 ACCESSORIES

THANK YOU



This presentation has been prepared by ARB Corporation Limited (ARB).  
The information in this presentation is current as at 8 May 2024.

This presentation is not an offer or invitation for subscription or purchase of securities or a recommendation with respect to any security. Information in this presentation should not be considered advice and does not take into account the investment objectives, financial situation and particular needs of an investor. Before making an investment in ARB any investor should consider whether such an investment is appropriate to their needs, objectives and circumstances and consult with an investment adviser if necessary. Past performance is not a reliable indication of future performance.

ARB has prepared this presentation based on information available to it. No representation or warranty, express or implied, is made as to the fairness, accuracy, completeness or correctness of the information, opinions and conclusions contained in this presentation.

To the maximum extent permitted by law, none of ARB, its directors, employees or agents, nor any person accepts any liability, including, without limitation, any liability arising from fault or negligence on the part of any of them or any other person, for any loss arising from the use of this presentation or its contents or otherwise arising in connection with it.

This presentation may contain forward looking statements that are subject to a range of risk factors and uncertainties. Whilst the statements are considered to be based on reasonable assumptions, the statements themselves and the assumptions upon which they are based may be affected by a range of circumstances which could cause actual results to differ significantly from the results expressed or implied in these forward-looking statements.